

## TROUBLESHOOTING FREQUENTLY ASKED QUESTIONS

TROUBLESHOOTING		
TROUBLE	PROBABLE CAUSE	SOLUTION
• Unit does not turn on.	<ul style="list-style-type: none"> <li>⚡ Not plugged in.</li> <li>⚡ Outlet not functioning.</li> </ul>	<ul style="list-style-type: none"> <li>✓ Plug in unit.</li> <li>✓ Have outlet replaced by a licensed electrician.</li> </ul>
• Mist output minimal to none.	<ul style="list-style-type: none"> <li>⚡ Cool mist is invisible.</li> <li>⚡ The filter has not absorbed water.</li> </ul>	<ul style="list-style-type: none"> <li>✓ Operate in High (3) setting.</li> <li>✓ Wait 30 minutes for filter to absorb water.</li> </ul>
• Filter turns brown.	<ul style="list-style-type: none"> <li>⚡ The filter has absorbed minerals.</li> </ul>	<ul style="list-style-type: none"> <li>✓ Replace your filter (HWF75/HF221) by calling 1-800-546-5637, or visiting <a href="http://www.holmesproducts.com">www.holmesproducts.com</a>.</li> </ul>

FREQUENTLY ASKED QUESTIONS	
Question	Answer
• What are the variables that affect run time?	<p>The estimated run time for this humidifier is based on average room conditions. The actual run time of your humidifier is dependent on numerous variables such as:</p> <ul style="list-style-type: none"> <li>✓ Air exchange in the room where the humidifier is placed.</li> <li>✓ Room construction of the room where the humidifier is placed.</li> <li>✓ Temperature of the room where the humidifier is placed.</li> <li>✓ Humidity levels in the room where the humidifier is placed.</li> <li>✓ Movement of occupants and the opening and closing of doors in the room where the humidifier is placed.</li> <li>✓ Home furnishings in the room where the humidifier is placed.</li> </ul>
• How do I remove film on water tank?	<ul style="list-style-type: none"> <li>✓ See Daily Maintenance instructions. Regular cleaning is recommended.</li> </ul>
• How can I extend the run time?	<ul style="list-style-type: none"> <li>✓ Run your unit on the lowest setting.</li> <li>✓ If your unit has electronics, set it to your desired humidity level. The unit will turn on and off, which will extend the run time.</li> <li>✓ Fill the tank all the way full, place it on the base, let the water empty into the base until it stops bubbling, then refill the tank full again. This ensures maximum water capacity and will extend run time.</li> </ul>

## CLEANING / MAINTENANCE

### Weekly Maintenance

#### To Remove Scale:

1. Repeat steps 1-4 above.
2. Partially fill the base with Cleanse Clean® solution (Model S1710) as instructed on bottle, or with two 8 oz. cups of undiluted white vinegar. Leave this solution in the base for 20 minutes, while cleaning all the interior surfaces with a soft brush. Remove base scale by wiping the base with a cloth dampened with undiluted white vinegar.
3. Rinse with clean warm water to remove the cleaning solution before disinfecting the tank.

#### To Disinfect Humidifier Base Tanks:

1. Fill Humidifier Base with 2 gallons of water and 1 teaspoon of chlorine bleach.
2. Fill each tank 1/2 full with water and 1 teaspoon of chlorine bleach.
3. Let the solution stand for 20 minutes, swishing every few minutes. Wet all surfaces.
4. Carefully empty the Base and Tanks after 20 minutes, and rinse with warm water until you cannot detect any bleach smell. Dry with a clean cloth or paper towel.
5. Depending on the water hardness in your area, it may be necessary to change the filter every 1-2 months. Re-insert the wick filter into the filter support.
6. Refill the water tanks as directed with cool tap water, replace the humidifier housing, and turn the Control Knob to ON.

### STORAGE INSTRUCTIONS

If your humidifier will not be in use for two days or more, or at the end of the season follow these instructions.

1. Clean, rinse and thoroughly dry the humidifier as directed in weekly maintenance. DO NOT leave any water inside the base or tray.
2. Remove the tank cap. Do not store with the tank cap in place.
3. Place the humidifier in the original carton and store in a cool, dry place.
4. Always clean the humidifier before the next season begins.
5. Order your replacement filter for next year's use.

### REPLACEMENT ACCESSORIES

To order the replacement accessories you can do any of the following:

- Visit your local retailer
- Go to [www.holmesproducts.com](http://www.holmesproducts.com)
- Call Consumer Service at 1-800-546-5637

If you have any questions regarding your product or would like to learn more about other Holmes® products, please contact our Consumer Service Department at 1-800-546-5637 or visit our website at [www.holmesproducts.com](http://www.holmesproducts.com).

© 2011 Sunbeam Products, Inc. doing business as Jarden Consumer Solutions. All Rights Reserved.  
Distributed by Sunbeam Products, Inc. doing business as Jarden Consumer Solutions, Boca Raton, Florida 33431.

150114/9100030007512  
GCDS-HOL20980-JC

HM350111EM1

Printed In China

## WARRANTY INFORMATION

### 1 YEAR LIMITED WARRANTY

Sunbeam Products, Inc. doing business as Jarden Consumer Solutions or if in Canada, Sunbeam Corporation (Canada) Limited doing business as Jarden Consumer Solutions (collectively "JCS") warrants that for a period of one year from the date of purchase, this product will be free from defects in material and workmanship. JCS, at its option, will repair or replace this product or any component of the product found to be defective during the warranty period. Replacement will be made with a new or remanufactured product or component. If the product is no longer available, replacement may be made with a similar product of equal or greater value. This is your exclusive warranty. Do NOT attempt to repair or adjust any electrical or mechanical functions on this product. Doing so will void this warranty.

This warranty is valid for the original retail purchaser from the date of initial retail purchase and is not transferable. Keep the original sales receipt. Proof of purchase is required to obtain warranty performance. JCS dealers, service centers, or retail stores selling JCS products do not have the right to alter, modify or any way change the terms and conditions of this warranty.

This warranty does not cover normal wear of parts or damage resulting from any of the following: negligent use or misuse of the product, use on improper voltage or current, use contrary to the operating instructions, disassembly, repair or alteration by anyone other than JCS or an authorized JCS service center. Further, the warranty does not cover: Acts of God, such as fire, flood, hurricanes and tornadoes.

#### What are the limits on JCS's Liability?

JCS shall not be liable for any incidental or consequential damages caused by the breach of any express, implied or statutory warranty or condition.

Except to the extent prohibited by applicable law, any implied warranty or condition of merchantability or fitness for a particular purpose is limited in duration to the duration of the above warranty.

JCS disclaims all other warranties, conditions or representations, express, implied, statutory or otherwise.

JCS shall not be liable for any damages of any kind resulting from the purchase, use or misuse of, or inability to use the product including incidental, special, consequential or similar damages or loss of profits, or for any breach of contract, fundamental or otherwise, or for any claim brought against purchaser by any other party.

Some provinces, states or jurisdictions do not allow the exclusion or limitation of incidental or consequential damages or limitations on how long an implied warranty lasts, so the above limitations or exclusion may not apply to you.

This warranty gives you specific legal rights, and you may also have other rights that vary from province to province, state to state or jurisdiction to jurisdiction.

#### How to Obtain Warranty Service

In the U.S.A.

If you have any question regarding this warranty or would like to obtain warranty service, please call 1-800-546-5637 and a convenient service center address will be provided to you.

In Canada

If you have any question regarding this warranty or would like to obtain warranty service, please call 1-800-546-5637 and a convenient service center address will be provided to you.

In the U.S.A., this warranty is offered by Sunbeam Products, Inc. doing business as Jarden Consumer Solutions located in Boca Raton, Florida 33431. In Canada, this warranty is offered by Sunbeam Corporation (Canada) Limited doing business as Jarden Consumer Solutions, located at 20 B Hereford Street, Brampton, Ontario L6Y 0M1. If you have any other problem or claim in connection with this product, please write our Consumer Service Department. **PLEASE DO NOT RETURN THIS PRODUCT TO ANY OF THESE ADDRESSES OR TO THE PLACE OF PURCHASE.**

# Holmes®

Owner's Guide  
HM3501

☎ INFO HOT-LINE: If, after reading this owner's guide you have any questions or comments, please call 1-800-546-5637 and a Customer Service Representative will be happy to assist you.

FILTER# : HWF75/HF221  
FILTER TYPE : WICK



Cool Mist  
**Humidifier**

**PLEASE READ AND SAVE THESE IMPORTANT INSTRUCTIONS**

## PLEASE READ AND SAVE THESE IMPORTANT SAFETY INSTRUCTIONS

When using electrical appliances, basic safety precautions should always be followed to reduce the risk of fire, electric shock, and injury to persons, including the following:

1. Read all instructions before using the appliance.
2. To avoid fire or shock hazard, plug the appliance directly into a 120V AC electrical outlet.
3. Keep the cord out of heavy traffic areas. To avoid fire hazard, NEVER put the cord under rugs or near heat registers.
4. DO NOT place humidifier near heat sources such as stoves, radiators, and heaters. DO locate your humidifier on an inside wall near an electrical outlet. The humidifier should be at least 4 inches (10 cm) away from the wall for best results.
5. NEVER place humidifier in an area where it is accessible to children. NEVER use humidifier in a closed room, particularly where a child may be sleeping, resting, or playing (a closed room may result in excessive humidity).
6. **WARNING:** Do not attempt to refill humidifier without first unplugging the unit from its electrical outlet. Failure to heed this warning may cause personal injury. Be sure to unplug the unit by pulling on the plug and not the cord.
7. Never place anything over moisture outlet when the unit is running.
8. NEVER drop or insert any object into any openings.
9. DO NOT operate any appliance with a damaged cord or plug, after the appliance malfunctions, or if it has been dropped or damaged in any manner. Return appliance to manufacturer for examination, electrical or mechanical adjustment, or repair.
10. Use appliance only for intended household use as described in this manual. Any other use not recommended by the manufacturer may cause fire, electric shock, or injury to persons. The use of attachments not recommended or sold by the manufacturer may cause hazards.
11. DO NOT use outdoors.
12. Always place humidifier on a firm, flat, level surface. A waterproof mat or pad is recommended for use under the humidifier. NEVER place it on a rug or carpet, or on a finished floor that may be damaged by exposure to water or moisture.
13. DO NOT allow the Moisture Outlet to directly face the wall. Moisture could cause damage, particularly to wallpaper.
14. Humidifier should be unplugged when not in use.
15. NEVER tilt, move, or attempt to empty unit while it is operating. Shut off and unplug before removing the water tank and moving the unit.
16. This humidifier requires daily and weekly maintenance to operate appropriately. Refer to daily and weekly cleaning procedures. Use only cleaners and additives recommended by the manufacturer.
17. NEVER use detergents, gasoline, glass cleaner, furniture polish, paint thinner, or other household solvents to clean any part of the humidifier.
18. Excessive humidity in a room can cause water condensation on windows and some furniture. If this happens, turn the humidifier OFF.
19. Do not use humidifier in an area where humidity level is in excess of 50%. Use a hygrometer, available at your local retailer or through the manufacturer, to measure the humidity.
20. DO NOT attempt to repair or adjust any electrical or mechanical functions on this unit. Doing so will void your warranty. The inside of the unit contains no user serviceable parts. All servicing should be performed by qualified personnel only.
21. Never place housing under water flow or immerse in liquids.
22. Do not plug in the cord with wet hands: electric shock could result.
23. Do not pour water in any openings other than the water tank.
24. To prevent damage to surfaces, do not place humidifier under overhanging surfaces.
25. NEVER operate unit without water in the tank.

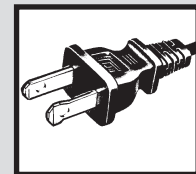

**THIS APPLIANCE HAS A POLARIZED PLUG (one blade is wider than the other). To reduce the risk of electric shock, this plug is intended to fit in a polarized outlet only one way. If the plug does not fit fully in the outlet, reverse the plug. If it still does not fit, contact a qualified electrician to install the proper outlet.**

**DO NOT ATTEMPT TO MODIFY THIS PLUG OR DEFEAT THIS SAFETY FEATURE IN ANY WAY.**

## FEATURES - OPERATIONS

26. Do not move unit after it has been used until unit cools completely.
27. Use both hands when carrying full tank of water.

## PLEASE READ AND SAVE THESE IMPORTANT SAFETY INSTRUCTIONS

### CONSUMER SAFETY INFORMATION

**NOTE:** This is an electrical appliance and requires attention when in use.

**NOTE:** If moisture forms on the walls or windows of the room, turn off the humidifier. The room already has plenty of humidity and additional moisture may cause damage.

**NOTE:** DO NOT block air inlet or outlet.

### Cord and Plug Installation Safety Instructions:

The length of cord used on this appliance was selected to reduce the hazards of becoming tangled in, or tripping over a longer cord. If a longer cord is necessary an approved extension cord may be used. The electrical rating of the extension cord must be equal to or greater than the rating of the humidifier (refer to the rating information placed on the humidifier). Care must be taken to arrange the extension cord so that it will not drape over the countertop or tabletop where it can be pulled on by children or accidentally tripped over.

### HOW COOL MIST WORKS

Your Holmes® Cool Mist humidifier draws dry air through the rear air intake grill area. This air is then passed through a moisture-laden wick filter, which retains the minerals and deposits in the water. The resulting moist air is directed back into the room from the top air grill.

**NOTE:** This humidification system provides a cool, invisible moisture output. It is normal not to see the mist.

**NOTE:** A humidity level below 20% can be unhealthy and uncomfortable. The recommended humidity level is between 40%-50%.

### PRE-OPERATING INSTRUCTIONS

1. Be sure the humidifier is switched to OFF and the unit is disconnected from the electrical outlet.
2. Remove housing, filter and tanks (See Figures 2 and 3).
3. TO PROVIDE ADDITIONAL MOBILITY AND CONVENIENCE TO YOUR CONSOLE HUMIDIFIER, install the wheels. Remove the four wheels located in a small pouch in the box. Turn the base upside down, and locate the holes at each of the four corners on the underside.

Figure 1

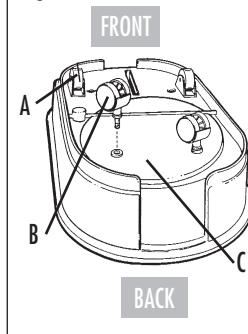

### WHEEL INSTALLATION

- A. STATIONARY WHEELS (INSTALL BELOW AIR INTAKE GRILLS)
- B. SWIVEL WHEELS (INSTALL BELOW WATER TANKS)
- C. UNDER-SIDE OF HUMIDIFIER BASE

**NOTE:** You will notice that there are two different shaped wheels. Two of the 4 wheels are stationary wheels and two are swivel type wheels. The stationary wheels are identified by a flat top surface, while the swivel type are curved and include a small plastic piece on the shaft. See figure 1 for installation location for each type of wheel. DO NOT use any tools to install the wheel because tools may damage the base of the unit. Return the base to the upright position. After installation, please check if the 2 stationary wheels are placed properly below the air intake grills, while the 2 swivel wheels are placed on the back side, below the water tanks (see Figure 2).

4. Replace filter, housing and tanks.
5. Select current month (JAN, FEB, ..., DEC) on the Filter Reminder Dial (see figure 2). For example, if the current month is January, scroll to select JAN. This will serve as reference for when filter replacement is needed.
6. Choose a location out of reach of children. DO NOT place the humidifier on a finished floor or near furniture which can be damaged by moisture or water.

## FEATURES - OPERATIONS

### FILLING THE WATER TANKS

1. Remove the two tanks from the base of the humidifier and bring each tank to the faucet. Turn the tanks upside down and twist off the tank caps by turning counter-clockwise. Fill each tank with cool, fresh tap water. Replace the cap on each tank FIRMLY.

Figure 2

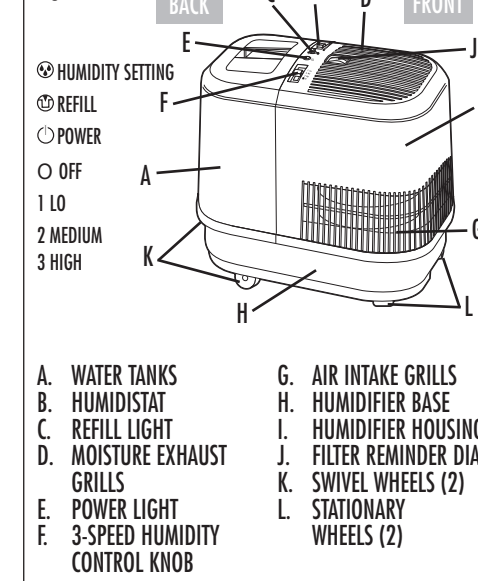

- |                                  |                          |
|----------------------------------|--------------------------|
| A. WATER TANKS                   | G. AIR INTAKE GRILLS     |
| B. HUMIDISTAT                    | H. HUMIDIFIER BASE       |
| C. REFILL LIGHT                  | I. HUMIDIFIER HOUSING    |
| D. MOISTURE EXHAUST GRILLS       | J. FILTER REMINDER DIAL  |
| E. POWER LIGHT                   | K. SWIVEL WHEELS (2)     |
| F. 3-SPEED HUMIDITY CONTROL KNOB | L. STATIONARY WHEELS (2) |

Figure 3

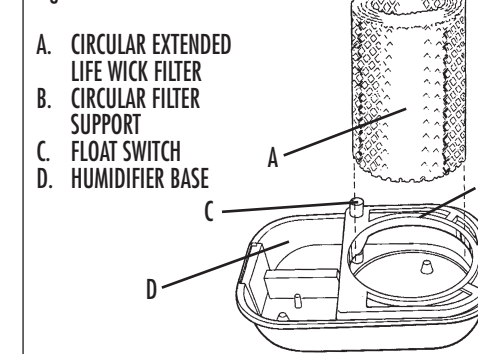

- A. CIRCULAR EXTENDED LIFE WICK FILTER
- B. CIRCULAR FILTER SUPPORT
- C. FLOAT SWITCH
- D. HUMIDIFIER BASE

**NOTE:** Adding a water softening agent like Water Treatment (Model S-1705) to the water will soften mineral deposits and prevent lime and scale build-up. It will also help prolong the life of the wick filter and make cleaning easier.

2. When full, carry each tank to the humidifier and place onto the base (use both hands when carrying each tank). Each tank holds 2.2 gallons of water, and the base holds 2 gallons of water. WHEN THE TANKS ARE FULL AND PLACED INTO THE BASE, YOU CAN HEAR THE WATER SLOWLY EMPTY INTO THE BASE. When the water stops emptying, remove the tanks and refill each again. Replace the tanks into the base. The WATER LIMITING feature on the tank cap will prevent the tanks from overflowing into the base. YOU NOW HAVE 2.2 GALLONS OF WATER IN EACH TANK AND 2 GALLONS OF WATER IN THE BASE OF THE HUMIDIFIER FOR A TOTAL OF 6.4 GALLONS OF WATER.
3. Plug the power cord into a 120V AC electrical outlet.

### OPERATING INSTRUCTIONS

With housing placed properly onto the base, the filter installed correctly, the tanks filled and the plug correctly inserted in the outlet, you are now ready to operate the humidifier.

**NOTE:** The humidifier produces clean, cool, INVISIBLE moisture. It is normal not to see the moisture.

1. Switch the Humidity Control Switch to the HIGH position and slide the humidistat to HIGH.
2. Allow up to 30 minutes for the filter to fully absorb water and the unit to produce the maximum moisture output.
3. Adjust the 3-speed Humidity Control Knob and the Humidistat as desired.
4. The Automatic Humidistat Control is designed to operate between 25% and 60% Relative Humidity range. The recommended setting is between 40% and 50%. When the humidity level in the room is below the level you have set, the humidifier will operate to produce moisture. When the set humidity level in the room is reached, the humidifier will stop. When the humidity again drops below the set level, the unit will automatically start and produce moisture again.
5. When the water level is low, the refill light will illuminate to indicate the unit needs refilling. Shut off and unplug the unit.

## FEATURES - OPERATIONS CLEANING / MAINTENANCE

**NOTE:** THE FAN WILL CONTINUE TO RUN TO ALLOW THE HUMIDIFIER TO DRY OUT AND PREVENT ALGAE GROWTH.

6. Before refilling, follow Daily Maintenance Instructions.
7. Refill water tanks.
8. Plug into the electrical outlet. Turn the Humidity Control Knob to the HIGH, MED, or LOW setting.

**NOTE:** If moisture forms on the walls or windows, turn off the humidifier.

### REPLACING THE FILTER

Through normal use, waterborne minerals and sediment become trapped in the wick filter. The harder your water, the greater the amount of minerals in the water, and the more often you will need to change your filter.

Use Filter Reminder Dial to keep track on how long a filter has been in use.

Filter Life – Under normal conditions of continuous use, a brand new filter will operate efficiently for 1 month. It is strongly recommended that a new filter be replaced every 30 days of use.

### To replace the filter, follow the steps below:

1. Be sure the humidifier is switched OFF and the unit is disconnected from the electrical outlet.
2. Remove the tank and main housing to access the base tray.
3. Discard the old filter and follow weekly cleaning instructions.
4. Insert a new filter into the filter support in the base.
5. Replace the main housing and then the tank.
6. Reset the Filter Reminder Dial by turning the wheel to select the current month (JAN-DEC).
7. Repeat Operating Instruction steps.

It will take about 30 minutes for the humidifier to reach maximum output.

**NOTE:** You can purchase replacement filters (model HWF75 / HF221) at a local retailer, by calling 1-800-546-5637, or by visiting [www.holmesproducts.com](http://www.holmesproducts.com). It is recommended that a replacement filter is purchased for uninterrupted use.

### CLEANING AND MAINTENANCE INSTRUCTIONS

Humidifiers provide comfort by adding moisture to dry, heated indoor air. To benefit most from the humidifier and avoid product misuse, follow all instructions carefully. Please note that this is an electrical appliance and requires attention when in use.

In addition, if you do not follow the recommended care and maintenance guidelines, micro-organisms may be able to grow in the water within the water tank. You must routinely follow the cleaning procedures that follow in order to ensure proper, efficient operation of your humidifier. Proper maintenance and cleaning is essential to the continued performance of your unit and the avoidance of algae or bacteria build-up.

### Daily Maintenance

1. Be sure the humidifier is switched OFF and the unit is disconnected from the electrical outlet.
2. Remove the housing and the tanks from the humidifier and place them in sink or tub.
3. Carry the base of the unit to the sink, remove the wick filter, place in sink, drain any remaining water and rinse thoroughly to remove any sediment or dirt. Wipe clean, and dry with a clean cloth or paper towel.
4. Drain the water from the tanks into the sink and rinse each tank thoroughly. Wipe clean, and dry with a clean cloth or paper towel.
5. Put filter back in the filter supports, replace the housing, then refill the tanks with cool tap water as instructed earlier in the Filling Instructions. Do not overfill.
6. Follow Operating Instructions.